

A. Current, Potential Difference and Resistance

1a A student builds a circuit. The circuit is shown in **Figure 1**.

Label the components shown in **Figure 1**. (3)

Figure 1

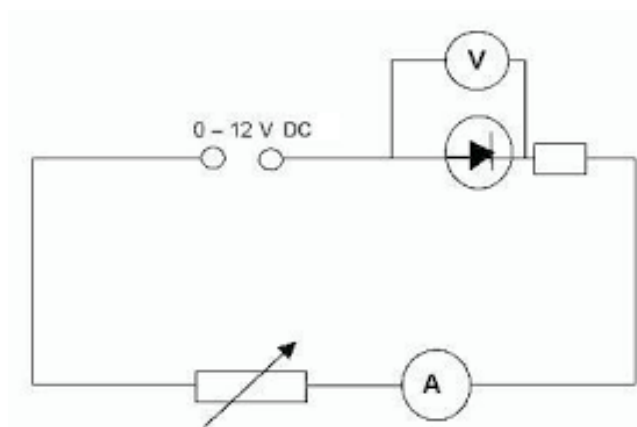

1b A resistor adds resistance to a circuit.

Describe what the effect of adding resistance would have on the current flowing in the circuit. (2)

1c In another electrical circuit a current of 1.2 A flows for 17 seconds.

Work out the charge flow in the circuit. Give the units of charge. (3)

2 A student sets up the circuit shown in **Figure 2** to measure the resistance of a resistor.

Figure 2

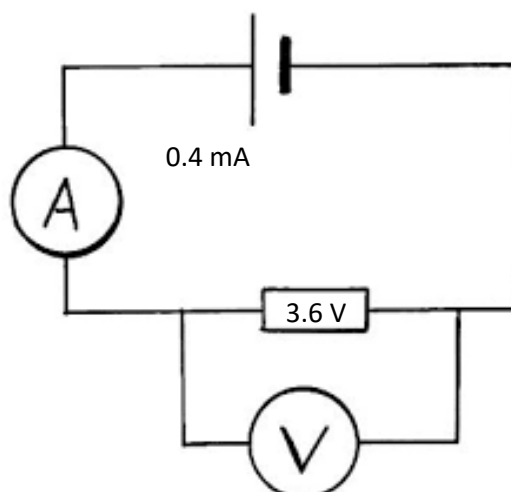

2a(i) Work out the resistance of the resistor in the circuit. (3)

2a(ii) The student adds a variable resistor into the circuit.

The variable resistor is used to get range of values for the potential difference and the current in the circuit.

Draw a graph to show how the potential difference and the current across the resistor are linked. Label this line **A**. (1)

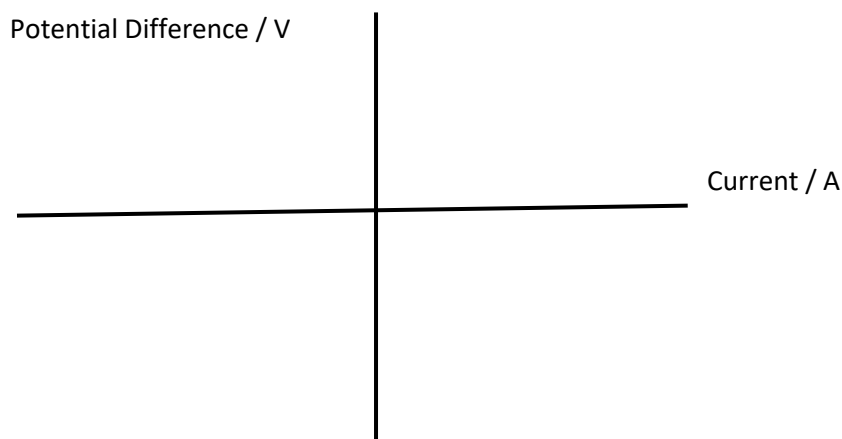

2a(iii) The resistor is replaced with a different resistor that has a lower value of resistance.

On the axes given for 2a(ii), draw a line to show how the current and the potential difference are now linked for this new resistor. Label this new resistor line **B**. (1)

2a(iv) A resistor is an ohmic conductor.

Explain what is meant by an ohmic conductor. (1)

2a(v) State the conditions required for the resistor to obey ohm's law. (1)

2b The resistor in **Figure 2** is replaced with a filament lamp.

The graph shown in **Figure 3** shows how the current and potential difference are linked.

Figure 3

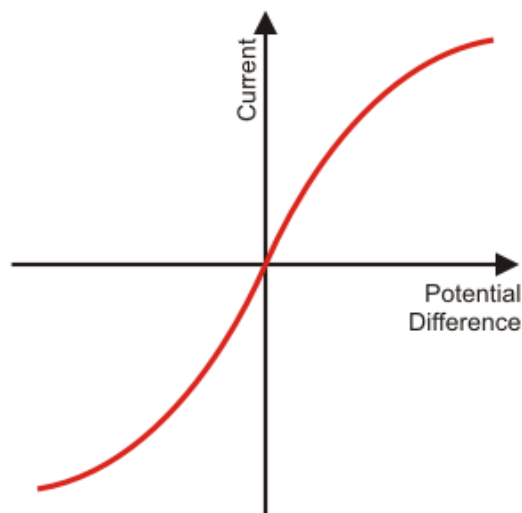

Explain the shape of the current - potential difference graph for a filament lamp. (6)

B. Series and Parallel Circuits

1a(i) A teacher wants to demonstrate the properties of series and parallel circuits. The teacher sets up a circuit with three identical filament lamps connected in series with a battery and an open switch. Draw the circuit that the teacher would set up. (3)

1a(ii) Each filament lamp has a resistance of 14Ω .
Work out the total resistance of the three filament lamps in series. (2)

1a(iii) The teacher now adds a fourth filament lamp in series with the other three. Describe the effect that adding this extra filament lamp will have on the circuit. (4)

1b The same four filament lamps are now placed into a parallel circuit. Describe how adding filament lamps in parallel affects the brightness of the filament lamps compared to the brightness of a single filament lamp. (1)

- 2a Six identical filament lamps are placed in a parallel circuit.
The current through each filament lamp is 3 A.

Work out the current drawn from the power supply. (2)

- 2b Two resistors, R_1 and R_2 , are placed in parallel.
 R_1 has a resistance of $120\ \Omega$ and R_2 has a resistance of $80\ \Omega$.
The total resistance of the two resistors is less than $80\ \Omega$.

Explain why adding resistors in parallel decreases the total resistance. (4)

C. Domestic Uses and Safety

1 Home electrical wiring uses three core electrical cables.

1a Match the name, colour and function of each wire. (3)

| Name of Wire | Colour of Wire | Function of Wire |
|--------------|----------------|-------------------------|
| Earth | Blue | Safety Wire |
| Live | Brown | To supply high voltage |
| Neutral | Yellow / Green | To complete the circuit |

1b(i) State the potential difference found in each wire when it is operating under normal conditions. (3)

Live:

Earth:

Neutral:

1b(ii) State the frequency of the mains electricity supply. (1)

1c The live wire can be dangerous even if a switch on the mains circuit is open. Explain why the live wire can still be dangerous. (3)

1d(i) Draw the output trace that you would get from a direct potential difference (dc) supply. (1)

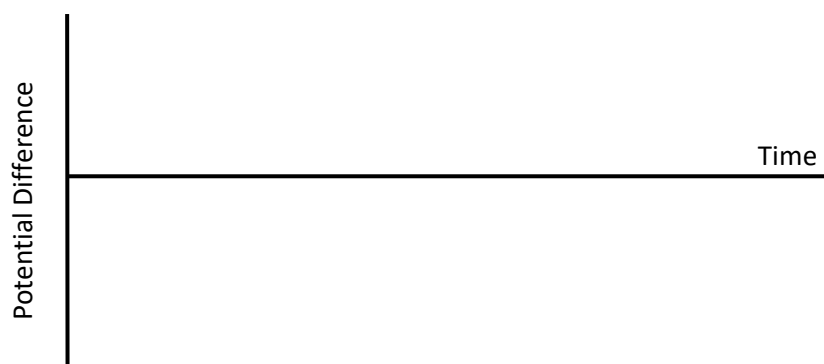

1d(ii) Draw the output trace that you would get from an alternating potential difference (ac) supply. (1)



D. Energy Transfers

1a A kettle has a power rating of 1.2 kW.
The kettle uses mains electricity at 230 V.

Work out the current flowing through the kettle. (4)

1b Describe the useful energy transfer that takes place in a kettle. (1)

1c Another kettle has a power rating of 1.5 kW.
This kettle takes 90 seconds to boil the water.

Work out the energy transferred by the kettle in the 90 seconds.

Give the correct unit with your answer. (4)

2a An electric motor is used to raise a lift.
The electric motor is connected to mains electricity at 230 V and has a power rating of 5 kW.
It takes the electric motor 35 seconds to raise the lift 20 meters.

Work out the charge flow in the electric motor. (4)

2b(i) Describe the useful energy changes that take place in an electric motor. (1)

2b(ii) Describe how energy is wasted in an electric motor. (2)

- 3a An overhead powerline is used to transmit electricity from power stations to our homes. A powerline carries a current of 350 A and has a power loss of 4 MW.

Work out the resistance of the powerline. (4)

- 3b Explain why the current through the powerline is made as low as possible in The National Grid. (4)

- 3c Describe how the current is reduced before transmitting the electricity through the powerlines. (2)

E. Static Electricity

- 1 This question is about static electricity.

- 1a State the **two** types of static charge. (1)

- 1b(i) A plastic rod has been given a positive charge by rubbing the plastic rod on a cloth.

Explain how the plastic rod has been given a positive charge in terms of movement of particles. (2)

- 1b(ii) The charged plastic rod is placed above some fine dust particles.

Describe the effect that the charged rod will have on the dust. (1)

- 1c Xavi walks across a carpet.

Once Xavi has crossed the carpet he touches an earthed metal radiator and gets an electric shock.

Explain why Xavi gets an electric shock when he touched the earthed radiator. (3)

- 2 Static is used in the spray painting of car doors.
Figure 1 shows a car door being spray painted using static.

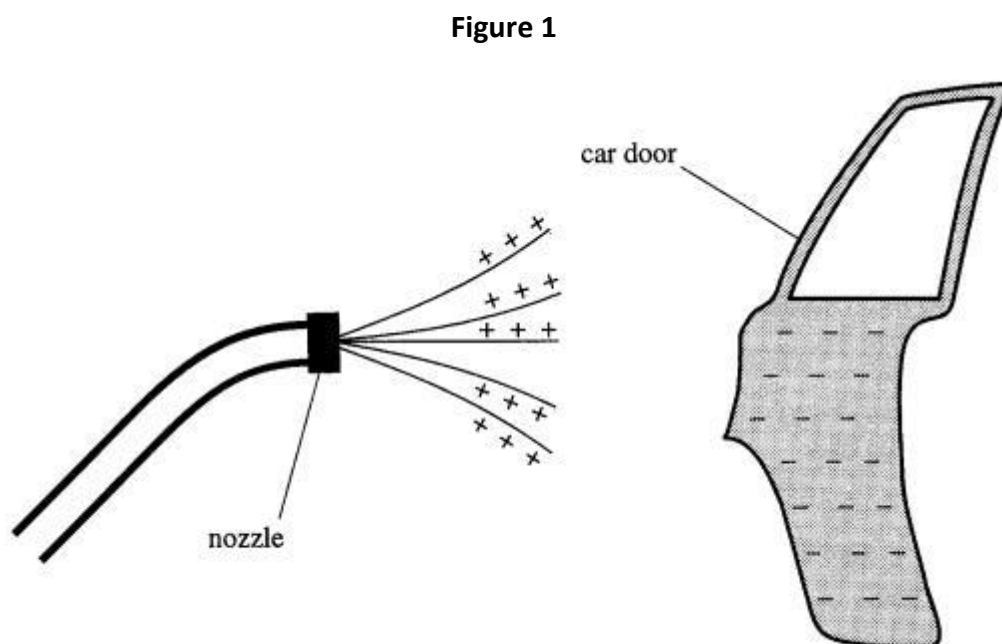

- 2a(i) Explain why electrostatic spray painting produces a fine spray. (3)
- 2a(ii) Explain why the car door has a negative charge. (3)
- 2a(iii) Suggest an advantage of electrostatic spray painting over the use of tins of spray paint. (1)
- 2b(i) A droplet of paint has been given a positive charge.
Draw the electric field for this paint droplet. (1)
- 2b(ii) Describe what would happen if another positively charged particle was placed into this electric field. (2)
- 2c A spark is formed when a charged object is earthed.
Explain why the spark forms. (3)