

Current and Circuits

It's pretty bad news if the word **current** makes you think of delicious cakes instead of physics. Learn what it means, as well as some handy **symbols** to show items like **batteries** and **switches** in a circuit.

Current is the Flow of Electrical Charge

- 1) **Current** is the **flow** of electric charge (e.g. electrons, p.49) around the circuit. Current will **only flow** through an electrical component if there is a **potential difference** across that component, and if the circuit is **complete** (closed). Unit: **ampere**, A.
- 2) **Potential difference** (or voltage) is the **driving force** that **pushes** the charge round. Unit: **volt**, V.
- 3) **Resistance** is anything that **slows the flow** down. Unit: **ohm**, Ω .
- 4) The current flowing **through a component** depends on the **potential difference** across it and the **resistance** of the component (p.72).

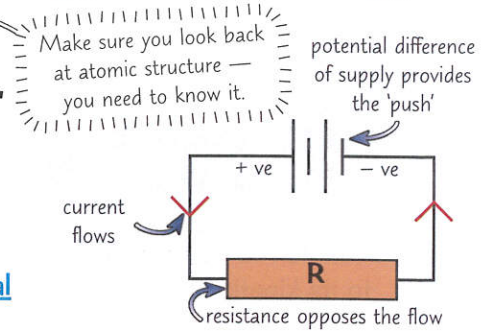

Generally speaking, the **higher the potential difference** across a given component, the **higher the current** will be. And the **greater the resistance** of a component, the **smaller the current** that flows (for a given potential difference across the component). There's more on resistance on p.72.

Total Charge Through a Circuit Depends on Current and Time

- 1) **Current** is the **rate of flow** of **charge**. In **metals**, the current is caused by a flow of **electrons**.
- 2) If a **current** (I) flows past a point in a circuit for a length of **time** (t), then the **charge** (Q) that has passed this point is given by this formula:

charge = current \times time

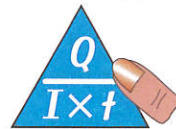

More charge passes around the circuit in a given time when a greater current flows.

- 3) To use this formula, you need **current** in **amperes**, A, **charge** in **coulombs**, C, and **time** in **seconds**, s.

EXAMPLE:

A battery passes a current of 0.25 A through a light bulb over a period of 4 hours. How much charge does the battery transfer through the bulb altogether?

charge = current \times time = $0.25 \times (4 \times 60 \times 60) = 3600 \text{ C}$

Watch out for units — your time needs to be in seconds if you're calculating charge.

Circuit Symbols You Should Know

You need to be able to use these symbols to **interpret** and **draw circuit diagrams**.

There's more about a.c. and d.c. on p.79.

cell 	battery 	open switch 	closed switch 	filament lamp 	fuse 	LED 	power supply d.c. a.c.
resistor 	variable resistor 	ammeter 	voltmeter 	diode 	LDR 	thermistor 	motor

I think it's about time you took charge...

Electrons in circuits actually move from -ve to +ve, but it's conventional to draw current as though it's flowing from +ve to -ve. It's what early physicists thought (before they found out about the electrons), and it's stuck.

Q1 Calculate how long it takes a current of 2.5 A to transfer a charge of 120 C. [2 marks]

Potential Difference and Resistance

As current flows round a circuit, the charges **transfer energy** as they struggle against **resistance**.

Potential Difference is the Energy Transferred Per Unit Charge

- 1) The **potential difference** is the **energy transferred per coulomb of charge** that passes between **two points** in an electrical circuit.
- 2) You can calculate energy transferred, in joules, J, from charge moved, in C, and potential difference, in V, using **this formula**:

$$\text{energy transferred} = \text{charge moved} \times \text{potential difference}$$

$$E = Q \times V$$

- 3) So, the **potential difference** (p.d.) across an electrical component is the **amount of energy** transferred by that electrical component (e.g. the amount of energy transferred by a motor to its kinetic energy store) **per unit charge** passed. One **volt** is one **joule per coulomb**.
- 4) Potential difference is sometimes called **voltage**. They're the same thing.

Resistance, Potential Difference and Current: $V = I \times R$

For potential difference (V) in volts, V, current (I) in amps, A, and resistance (R) in ohms, Ω :

$$\text{potential difference} = \text{current} \times \text{resistance}$$

As a formula triangle:



If you **rearrange** this equation, you can use it to calculate the **resistance** of a component from measurements of **potential difference** and **current** (e.g. from the experiment on the next page).

EXAMPLE:

A 4.0Ω resistor in a circuit has a potential difference of 6.0 V across it. What is the current through the resistor?

Rearrange $V = IR$ to give $I = V \div R$, then **substitute** in the values you have. $I = 6.0 \div 4.0 = 1.5 \text{ A}$

Since the **current** of a circuit is affected by its **resistance**, you can use a **variable resistor** to change the current of a supply instead of using a **variable supply** like the one on the next page.

Resistance Increases with Temperature (Usually)

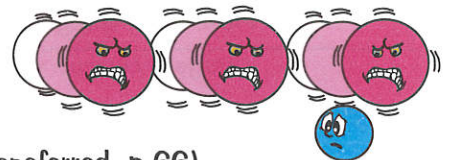

- 1) When an electrical charge flows through a component, it has to **do work against resistance**.
- 2) This causes an **electrical transfer of energy** (work done = energy transferred, p.66).
- 3) Some of this energy is transferred **usefully** (p.26) but some of it is **dissipated** to the **thermal** energy stores of the **component** and the **surroundings**.
- 4) So when a **current** flows through a **resistor**, the resistor **heats up**.
- 5) This happens because the **electrons collide with the ions** in the lattice that make up the resistor as they flow through it. This gives the ions **energy**, which causes them to **vibrate** and **heat up**.
- 6) The more the ions vibrate, the **harder** it is for electrons to get through the resistor (because there are more collisions). This means that for a **given p.d.** the current **decreases** as the resistor **heats up**.
- 7) If the resistor gets **too hot**, **no** current will be able to flow. There is one **exception** to this — the resistance of a **thermistor decreases** with an increase in temperature (p.74).

Low resistance wires (p.91) reduce the energy dissipated to thermal stores as the current flows between components.

In the end you'll have to learn this — resistance is futile...

$V = IR$ is one of the most useful equations in electricity — it crops up in a bunch of different places. So make sure you can bring it to mind super quickly and use it without trouble. Have a quick practise before moving on.

Q1 A current flowing through a resistor transfers 360 J of energy when 75 C of charge are passed through it. Calculate the potential difference across the resistor.

[2 marks]

Investigating Components

Ooh experiments, you've gotta love 'em. Here's a simple experiment for investigating different components.

The Standard Test Circuit

You can use this circuit to investigate the relationship between current (I) p.d. (V) and resistance for a range of components, such as a filament bulb or a fixed resistor. This relationship can be easily shown with an I - V graph — just like the ones over on the next page.

The standard test circuit contains:

- **Ammeter** — this measures the current (in amps) flowing through the component. It can be put anywhere in the main circuit — but it must be placed in series (p.75) with the component, never in parallel.
- **Voltmeter** — this measures the potential difference across the component. It must be placed in parallel (p.75) with the component under test.

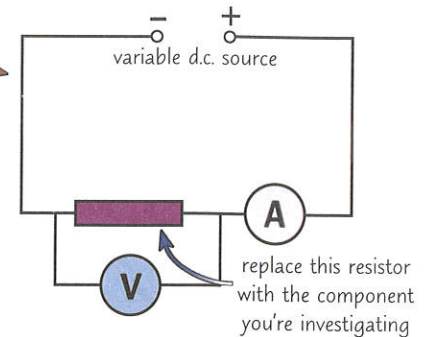

PRACTICAL

To use the circuit above to investigate a component, e.g. a fixed resistor or a filament lamp:

- 1) Connect the circuit as shown above. The component and the ammeter are in series, which means they can be put in any order in the main circuit. (Remember the voltmeter must be in parallel around the component under test.)
- 2) Change the output potential difference of the power supply. This alters the current flowing through the circuit and the potential difference across the component.
- 3) Take several pairs of readings from the ammeter and voltmeter to see how the current through the component varies as the potential difference across it is changed.
- 4) Plot the current against the potential difference to get I - V graphs like the ones on p.74.
- 5) You can use this data to work out the resistance for each measurement of I and V , using the formula on p.72, so you can see if the resistance of the component changes as I and V change.
- 6) Make sure the circuit doesn't get too hot over the course of your experiment, as this will mess up your results (p.72). If the circuit starts to warm up, disconnect it for a while between readings so it can cool down. And, like any experiment, you should do repeats and calculate means.

Have a look at page 7 for more about calculating averages and interpreting your results.

You Can Investigate Diodes, LDRs and Thermistors

You can also create I - V graphs for diodes, thermistors and LDRs using the method above (there's more about thermistors and LDRs on the next page). However, the resistance of these components (and so their potential difference) can depend on other factors besides current.

- 1) **Diodes** — after you've finished taking measurements for a range of currents, remove the diode and swap its direction. You should find that current cannot flow through the diode anymore (see p.74).
- 2) **Thermistors** — keeping the supply potential difference constant, gradually heat the thermistor. (You can do this by placing the thermistor against a beaker of hot water.) You should find that as the temperature increases, the current through the thermistor increases as the resistance decreases.
- 3) **LDRs** — conduct your experiment in a dim room. Again keep the p.d. of the supply constant and slowly adjust the light level near to the LDR (e.g. by using a lamp connected to a dimmer switch). You should find as the light level gets brighter, the current through the LDR increases as the resistance decreases.



Measure gymnastics — use a voltmeter...

Make sure you can describe the experiment above — remember, ammeters in series, voltmeters in parallel.

Q1 Draw a circuit you could use to create an I - V graph for a filament lamp.

[3 marks]

Circuit Devices

With your current and your potential difference measured, you can now make some **sweet** graphs...

Three Important Current-Potential Difference Graphs

I - V graphs show how the **current** varies as you **change** the **potential difference** (p.d.). Here are three examples, plotted from the experiment on the previous page:

RESISTORS AND WIRES

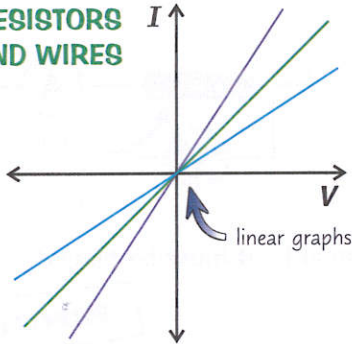

Current is **directly proportional to p.d.** (if the temperature stays the same).

Different resistors have different resistances, so their I - V graphs have different slopes.

FILAMENT LAMP

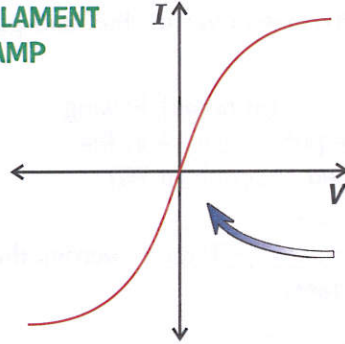

The increasing current increases the **temperature** of the filament, which makes the **resistance increase** (see p.72) so their I - V graphs are **curved**.

DIODE

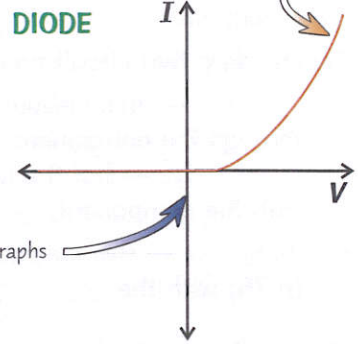

Current will only flow through a diode **in one direction**, as shown. The diode has very **high resistance** in the opposite direction.

- 1) **Linear** components have an I - V graph that's a **straight line** (e.g. a fixed resistor). **Non-linear** components have a **curved** I - V graph (e.g. a filament lamp or a diode).
- 2) For **linear** components, if the line goes through **(0,0)**, the resistance of the component equals the **inverse** of the **gradient** of the line, or " **$1/\text{gradient}$** ". The **steeper** the graph, the **lower** the resistance.
- 3) You can find the **resistance** for **any point** on any I - V graph by reading the **p.d.** and **current** at that point and sticking them into $V = IR$, p.72.

LDR is Short for Light Dependent Resistor

- 1) An LDR is a resistor that is **dependent** on the **intensity of light**. Simple really.
- 2) In **bright light**, the resistance **falls**.
- 3) In **darkness**, the resistance is **highest**.
- 4) They have lots of applications including **automatic night lights**, outdoor lighting and **burglar detectors**.

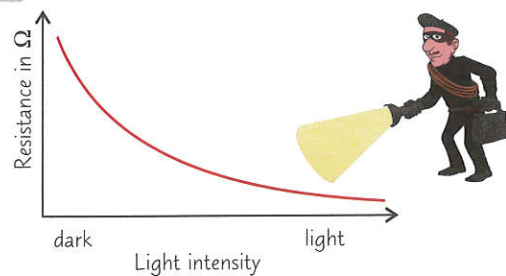
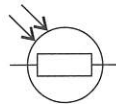

The Resistance of a Thermistor Decreases as Temperature Increases

- 1) A **thermistor** is a **temperature dependent** resistor.
- 2) In **hot** conditions, the resistance **drops**.
- 3) In **cool** conditions, the resistance goes **up**.
- 4) Thermistors make useful **temperature detectors**, e.g. **car engine** temperature sensors and electronic **thermostats**.

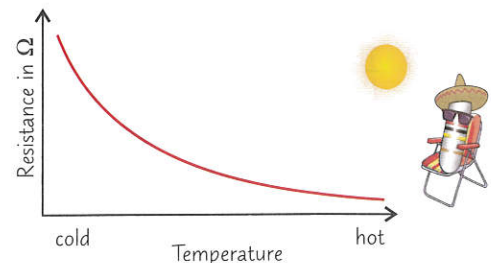

LDRs — Light Dependent Rabbits...

You may get given an I - V graph in your exam that you haven't seen before. Make sure you understand why these graphs have the shape they do, and you'll be ready for anything they throw at you.

Q1 Describe one everyday use for: a) an LDR b) a thermistor [2 marks]

Series and Parallel Circuits

Make sure you know the rules about what happens to current and p.d. in series and parallel circuits. You can find out how and why the resistance changes for both of these circuits over on the next page.

Series Circuits — All or Nothing

- 1) In series circuits, the different components are connected in a line, end to end, between the +ve and -ve of the power supply (except for voltmeters, which are always connected in parallel, but they don't count as part of the circuit).
- 2) If you remove or disconnect one component, the circuit is broken and they all stop working. This is generally not very handy, and in practice very few things are connected in series.
- 3) You can use the following rules to design series circuits to measure quantities and test components. For a series circuit:
 - There's a bigger supply p.d. when more cells are in series (if they're all connected the same way). E.g. when two batteries with a p.d. of 1.5 V are connected in series they supply 3 V between them.
 - The current is the same everywhere. $I_1 = I_2 = I_3$ etc. The size of the current depends on the total p.d. and the total resistance of the circuit ($I = V \div R$).
 - The total potential difference of the supply is shared between components. The p.d. for each component depends on its resistance.
 - The total resistance of the circuit increases as you add resistors (see next page).

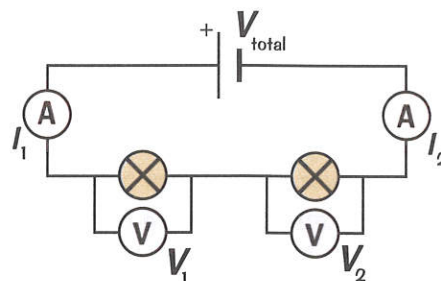

Parallel Circuits — Everything is Independent

- 1) In parallel circuits, each component is separately connected to the +ve and -ve of the supply (except ammeters, which are always connected in series).
- 2) If you remove or disconnect one of them, it will hardly affect the others at all.
- 3) This is obviously how most things must be connected, for example in cars and in household electrics. You have to be able to switch everything on and off separately.
- 4) Everyday circuits often contain a mixture of series and parallel parts — when looking at components on the same branch the rules for series circuits apply.
- 5) For a parallel circuit:
 - The potential difference is the same across all components. $V_1 = V_2 = V_3$ etc.
 - Current is shared between branches. The total current flowing around the circuit is equal to the total of all the currents through the separate components. $I_{\text{total}} = I_1 + I_2$ etc.
 - In a parallel circuit, there are junctions where the current either splits or rejoins. The total current going into a junction has to equal the total current leaving. (If two identical components are connected in parallel then the same current will flow through each component.)
 - The total resistance of the circuit decreases if you add a second resistor in parallel (see p.76).

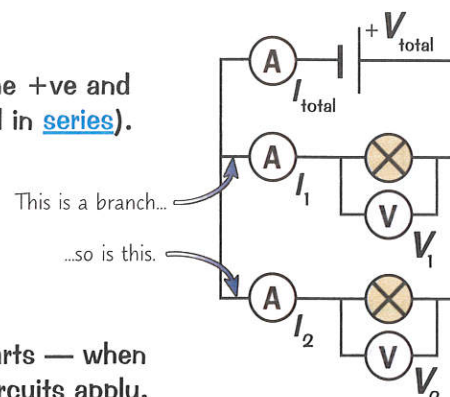

Series circuits — they're no laughing matter...

Get those rules straightened out in your head, then have a go at these questions to test what you can remember.

- Q1 A filament lamp and a resistor are connected in series. A current of 0.5 A flows through the lamp. State the current flowing through the resistor. [1 mark]
- Q2 Draw a circuit diagram for two filament lamps connected in parallel to a battery. Both of the lamps can be switched on and off without affecting each other. [3 marks]

More on Series and Parallel Circuits

Time for a bit more about series and parallel circuits, including a quick experiment. Fun, fun, fun...

Adding Resistors in Series Increases Total Resistance

- 1) In series circuits the total resistance of two components is just the sum of their resistances.
- 2) This is because by adding a resistor in series, the two resistors have to share the total p.d.
- 3) The potential difference across each resistor is lower, so the current through each resistor is also lower. In a series circuit, the current is the same everywhere so the total current in the circuit is reduced when a resistor is added. This means the total resistance of the circuit increases.
- 4) The bigger a component's resistance, the bigger its share of the total potential difference.

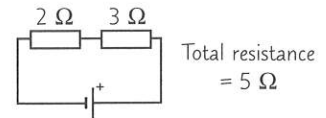

Adding a Resistor in Parallel Reduces the Total Resistance

- 1) If you have two resistors in parallel, their total resistance is less than the resistance of the smallest of the two resistors.
- 2) This can be tough to get your head around, but think about it like this:
 - In parallel, both resistors have the same potential difference across them as the source.
 - This means the 'pushing force' making the current flow is the same as the source p.d. for each resistor that you add.
 - But by adding another loop, the current has more than one direction to go in.
 - This increases the total current that can flow around the circuit. Using $V = IR$, an increase in current means a decrease in the total resistance of the circuit.

Use a Circuit to Investigate these Properties

- 1) Set out the circuit shown in the diagram on the right.
- 2) Vary the output potential difference from the power supply. Record the readings from the ammeter and voltmeter for each change.
- 3) Replace the resistor with a filament lamp and repeat step 2.
- 4) Now, connect a second filament lamp to the circuit, in parallel to the first. Connect ammeters and a second voltmeter, so you have:
- 5) Again, vary the output potential difference of the supply.
- 6) Write down the current through each ammeter and the p.d. across each component.

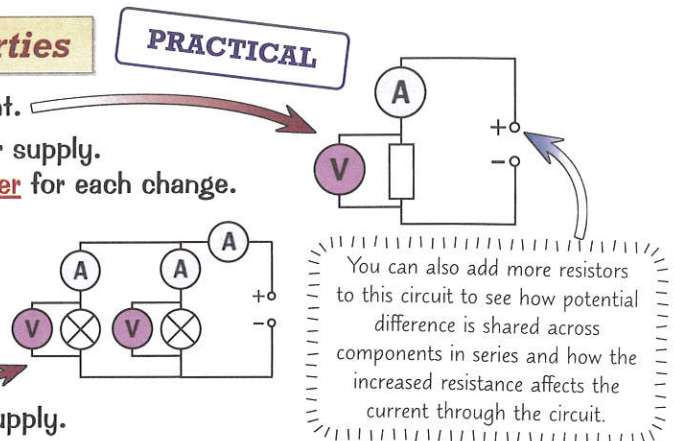

You can also add more resistors to this circuit to see how potential difference is shared across components in series and how the increased resistance affects the current through the circuit.

For the series circuit, you should find that as the potential difference increases, the current through the resistor increases. (Using $V = IR$ from page 72 — R for a fixed resistor is constant, so an increase in V causes an increase in I .) You should find a similar, but non-linear relationship between p.d. and current for a filament bulb (see p.74).

For the parallel circuit, you should find that as p.d. increases, so does the current through each bulb (again, this is a non-linear relationship). The p.d. across each bulb is the same as the p.d. of the power supply. You should also notice that the total current through the circuit is the sum of the current through the two branches and that this is larger than the total current through the series circuit with one filament bulb (the overall resistance of the parallel circuit is lower, see above — $V = IR$, so a lower value of R causes a higher value of I).

A current shared (between identical components) — is a current halved...

Parallel circuits are more complicated than series circuits but you need to learn about both I'm afraid.

- Q1 A 12 V cell is connected in series with a 2 Ω resistor, a 3 Ω resistor and a 7 Ω resistor. Calculate the current through the circuit.

[3 marks]

Energy in Circuits

Electrical devices are built to transfer energy. But nothing is perfect and some of this transferred energy ends up in thermal stores. This isn't always a bad thing though — devices like toasters and heaters make use of it.

Energy Transferred Depends on Current, p.d. and Time

- 1) When an electrical charge goes through a change in potential difference, then energy is transferred (as work is done against resistance — p.72).
- 2) Energy is supplied to the charge at the power source to 'raise' it through a potential.
- 3) The charge gives up this energy when it 'falls' through any potential drop in components elsewhere in the circuit.
- 4) To find the energy transferred to an electrical component, you can use the equation:

$$E = I \times V \times t$$

Where E is energy transferred in joules (J), I is current in amps (A), V is p.d. in volts (V) and t is time in seconds (s).

- 5) The larger the current through, or p.d. across, a component, the more energy is transferred to it.

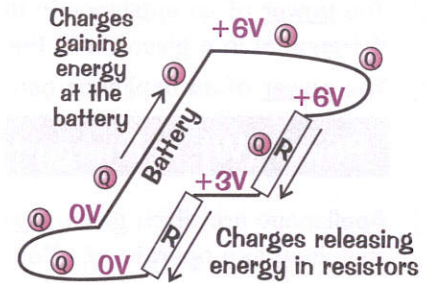

This equation comes from combining two of the equations from the next page.

Energy is Transferred from Cells and Other Sources

- 1) Electrical appliances are designed to transfer energy to components in the circuit when a current flows.

Kettles transfer energy electrically from the mains a.c. supply to the thermal energy store of the heating element inside the kettle.



Energy is transferred electrically from the battery of a handheld fan to the kinetic energy store of the fan's motor.

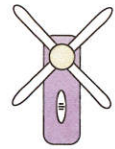

- 2) Of course, no appliance transfers all energy completely usefully. The higher the current, the more energy is transferred to the thermal energy stores of the components (and then the surroundings).
- 3) This heating usually increases the resistance of the components, like you saw on page 72.

Heating a Circuit isn't Always Bad

- 1) Heating up a component generally reduces its efficiency (p.26) — less energy is transferred to useful energy stores because more of it is being transferred to the thermal energy store of the component.
- 2) If the temperature gets too high, this can cause components in the circuit to melt — which means the circuit will stop working, or not work properly.
- 3) Fuses use this effect to protect circuits — they melt and break the circuit if the current gets too high.
- 4) The heating effect of an electric current can have other advantages. For example, it's ace if you want to heat something. Toasters contain a coil of wire with a really high resistance. When a current passes through the coil, its temperature increases so much that it glows and gives off infrared radiation. This radiation transfers energy to the bread and cooks it.
- 5) Filament bulbs and electric heaters work in a similar way.

More on fuses on p.80.

Have a break from all this work — or you'll have no energy left...

There's no escaping energy transfers I'm afraid. Practise using that equation then take a quick break to recharge.

- Q1 A laptop charger is connected to a 230 V source for an hour. A current of 8.0 A flows through it. Calculate the energy transferred by the laptop charger.

[2 marks]

Power in Circuits

You know that electrical devices transfer energy — well, their power determines how quickly this happens.

Energy Transferred Depends on Power

- 1) The total energy transferred by an appliance depends on how long the appliance is on for and its power.
- 2) The power of an appliance is the energy that it transfers per second. So the more energy it transfers in a given time, the higher its power.
- 3) The power of an appliance can be found using:

$$\text{Power (W)} = \text{Energy transferred (J)} \div \text{Time (s)}$$

$$P = \frac{E}{t}$$

- 4) Appliances are often given a power rating — they're labelled with the maximum safe power that they can operate at. You can usually take this to be their maximum operating power.
- 5) The power rating tells you the maximum amount of energy transferred between stores per second when the appliance is in use.

Microwaves have a range of power ratings. A microwave with a power rating of 500 W will take longer to cook food than one with a power rating of 750 W. This is because the 500 W transfers less energy per second to the thermal energy store of the food, so it takes longer to cook.

- 6) This helps customers choose between models — the lower the power rating, the less electricity an appliance uses in a given time and so the cheaper it is to run.
- 7) But, a higher power doesn't necessarily mean that it transfers more energy usefully. An appliance may be more powerful than another, but less efficient, meaning that it might still only transfer the same amount of energy (or even less) to useful stores (see p.26).

Power Also Depends on Current and Potential Difference

- 1) The power transferred by an appliance depends on the potential difference (p.d.) across it, and the current flowing through it.
- 2) The p.d. tells you how much energy each unit of charge transfers (p.72), and the current tells you how much charge passes per unit time. So both will affect the rate that energy is transferred to an appliance, and the rate at which it transfers energy to other stores.
- 3) The power of an appliance can be found with:

$$\text{Electrical power (W)} = \text{Current (A)} \times \text{Potential difference (V)}$$

$$P = IV$$

- 4) You can use this equation to work out the fuse (p.80) that should be used in an appliance. To work out the size of the fuse needed, you need to work out the current that the item will normally use:

EXAMPLE:

A 1 kW hair dryer is connected to a 230 V supply. Find the fuse needed.

- 1) Use the equation to find the normal current.
- 2) A fuse is usually rated just a little higher than the normal current.

$$I = P \div V = 1000 \div 230 = 4.3 \text{ A}$$

So a 5 amp fuse is needed.

- 5) You can also find the power if you don't know the potential difference. To do this, stick $V = IR$ from page 72 into $P = IV$, which gives you:

$$P = I^2R$$

Where P is the electrical power in watts (W), I is current in amperes (A) and R is the resistance in ohms (Ω).

You have the power — now use your potential...

I'm afraid the best way to learn all of this is to just practise using those equations again and again. Sorry.

- Q1 Calculate the difference in the amount of energy transferred by a 250 W TV and a 375 W TV when they are both used for two hours.

[3 marks]

Electricity in the Home

There are two types of electricity supply — alternating and direct currents. Read on for more about both...

Mains Supply is a.c., Battery Supply is d.c.

- 1) There are two types of electricity supplies — alternating current (a.c.) and direct current (d.c.).
- 2) In a.c. supplies the movement of the charges is constantly changing direction. Alternating currents are produced by alternating voltages (the positive and negative ends of the p.d. keep alternating).
- 3) The UK mains supply (the electricity in your home) is an a.c. supply at around 230 V.
- 4) The frequency of the a.c. mains supply is 50 cycles per second or 50 Hz (hertz).
- 5) By contrast, cells and batteries supply direct current (d.c.).
- 6) In direct current the movement of the charges is only in one direction. It's created by a direct voltage (a p.d. that is only positive or negative, not both).

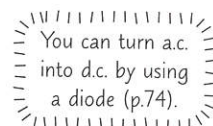

Most Cables Have Three Separate Wires

- 1) Most electrical appliances are connected to the mains supply by three-core cables. This means that they have three wires inside them, each with a core of copper and a coloured plastic coating.
- 2) The colour of the insulation on each cable shows its purpose.
- 3) The colours are always the same for every appliance. This is so that it's easy to tell the different wires apart.

2) NEUTRAL WIRE — blue.

The neutral wire completes the circuit — electricity normally flows in through the live wire and out through the neutral wire. The neutral wire is always at 0 V.

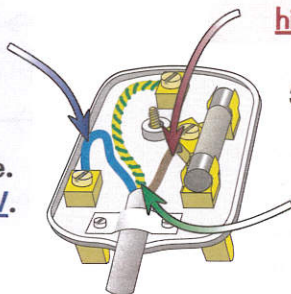

1) LIVE WIRE — brown.

The live wire carries the voltage (potential difference, p.d.). It alternates between a high +ve and -ve voltage of about 230 V.

3) EARTH WIRE — green and yellow.

The earth wire is for safety and protecting the wiring. It carries the current away if something goes wrong and stops the appliance casing becoming live. It's also at 0 V.

- The p.d. between the live wire and the neutral wire equals the supply p.d. (230 V for the mains).
- The p.d. between the live wire and the earth wire is also 230 V for a mains-connected appliance.
- There is no p.d. between the neutral wire and the earth wire — they're both at 0 V.

- 4) Plug sockets have switches which are connected in the live wire of the circuit. This is so the circuit can be broken — the appliance becomes isolated and the risk of an electric shock is reduced.

Touching the Live Wire Gives You an Electric Shock

- 1) Your body (just like the earth) is at 0 V.
- 2) This means that if you touch the live wire, a large potential difference is produced across your body and a current flows through you.
- 3) This causes a large electric shock which could injure or even kill you.
- 4) Even if a plug socket or a light switch is turned off (i.e. the switch is open) there is still a danger of an electric shock. A current isn't flowing, but there is still a p.d. in the live wire. If you made contact with the live wire, your body would provide a link between the supply and the earth, so a current would flow through you.
- 5) Any connection between live and neutral can be dangerous. If the link creates a low resistance path to earth, a huge current will flow, which could result in a fire.



Why are earth wires green and yellow — when mud is brown..?

Electricity is very useful, but it can also be very dangerous. Make sure you know the risks.

Q1 Explain the difference between a.c. and d.c. electricity supplies.

[2 marks]

Fuses and Earthing

Fuses and circuit breakers are super important. And questions on them cover a whole barrel of fun — electrical current, resistance, potential difference... Read this page and make sure you've got it sussed.

Earthing and Fuses Prevent Electrical Overloads

Surges (sudden increases) in current can occur because of changes in a circuit (e.g. an appliance suddenly switching off) or because of a fault in an electrical appliance. Current surges can lead to the circuits and wiring in your appliances melting or causing a fire, and faulty appliances can cause deadly electric shocks.

The earth wire and a fuse are included in electrical appliances to prevent this from happening. This is how they work:

- 1) If a fault develops in which the live wire somehow touches the metal case, then because the case is earthed, too great a current flows in through the live wire, through the case and out down the earth wire.
- 2) This surge in current melts the fuse when the amount of current is greater than the fuse rating. Fuses are connected to the live wire, so that breaking the fuse breaks the circuit and cuts off the live supply.
- 3) This isolates the whole appliance, making it impossible to get an electric shock from the case. It also prevents the risk of fire caused by the heating effect of a large current.
- 4) Fuses should be rated as near as possible but just higher than the normal operating current.
- 5) The larger the current, the thicker the cable you need to carry it (to stop the cable getting too hot and melting). That's why the fuse rating needed for cables usually increases with cable thickness.

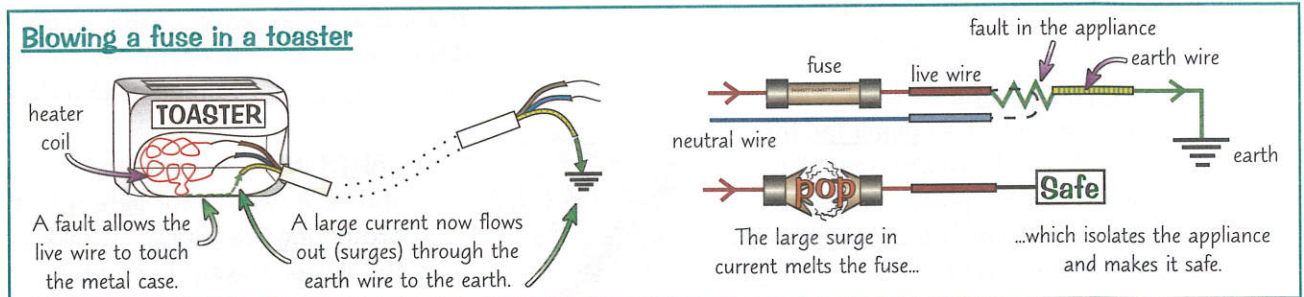

- 6) As well as the fuses in plugs, there are also household fuses (these are the ones that blow when a light bulb goes). These work in the same way, but protect the wiring in the house, not just in an appliance.

Circuit Breakers are Even Safer Than Fuses

Circuit breakers can be used in the place of household fuses.

- 1) Instead of melting a fuse, a large current may instead 'trip' (turn off) a circuit breaker.
- 2) Circuit breakers turn off quicker than the time taken for a fuse to melt.
- 3) They can also be reset, which is much easier than having to replace a fuse.
- 4) However, circuit breakers are more expensive than fuses.

Insulating Materials Make Appliances "Double Insulated"

- 1) All appliances with metal cases are usually "earthed" to reduce the danger of electric shock.
- 2) "Earthing" just means the case must be attached to an earth wire. An earthed conductor can never become live.
- 3) If the appliance has a plastic casing and no metal parts showing then it's said to be double insulated.
- 4) Anything with double insulation like that doesn't need an earth wire — just a live and neutral. Cables that only carry the live and neutral wires are known as two-core cables.

Nothing shocks my mum — she's very down to earth...

Earthing is dead important, so make sure you understand it and the life-saving protection it provides.

Q1 Which wire are fuses connected in?

[1 mark]

Revision Questions for Section 5

Well, that wraps up [Section 5](#) — time to have a go at a few questions to see how much you can remember.

- Try these questions and [tick off each one](#) when you [get it right](#).
- When you've done [all the questions](#) for a subtopic and are [completely happy](#) with it, tick off the topic.

Circuit Basics (p.71-74)

- 1) What is meant by potential difference and resistance in a circuit?
- 2) Define current and state an equation that links current, charge and time, with units for each.
- 3) Draw the circuit symbols for: a cell, a filament lamp, a diode, a motor and an LDR.
- 4) Give the equation that links energy transferred, charge moved and potential difference.
- 5) What is the equation that links potential difference, current and resistance?
- 6) Briefly explain why resistance increases with temperature for a resistor.
- 7) Explain how you would investigate how the current through a component affected its resistance.
- 8) True or false? An ammeter must be connected in parallel to the component being tested.
- 9) Name one linear component and one non-linear component.
- 10) Explain how the resistance of an LDR varies with light intensity.
- 11) Give one everyday use of an LDR.
- 12) What happens to the resistance of a thermistor as it gets hotter?

Series and Parallel Circuits (p.75-76)

- 13) How does the current through each component vary in a series circuit?
- 14) True or false? Potential difference is shared between components in a series circuit.
- 15) How does potential difference vary between components connected in parallel?
- 16) True or false? Adding resistors in series increases the total resistance of the circuit.
- 17) Does adding two resistors in parallel increase or decrease the total resistance of a circuit?

Power and Energy Transfers in Circuits (p.77-78)

- 18) Write down the equation that links energy transferred, current, potential difference and time.
- 19) Give two disadvantages of the heating effect in an electrical circuit.
- 20) Give two advantages of the heating effect in an electrical circuit.
- 21) Define power in terms of energy transferred.
- 22) What is a power rating?
- 23) State the equation that links electrical power, current and potential difference.
- 24) What is the third equation for electrical power, which links current and resistance?

Electricity in the Home and Electrical Safety (p.79-80)

- 25) True or false? Mains supply electricity is an alternating current.
- 26) What is the frequency of the UK mains supply?
- 27) Why are the three wires in a three-core cable colour coded?
- 28) Give the potential differences for the three wires in a three-core mains cable.
- 29) Explain why touching a live wire is dangerous.
- 30) Explain how a fuse protects you if a fault causes the live wire to touch the metal case of an appliance.
- 31) True or false? Circuit breakers must be replaced each time they 'trip'.